



Service Oriented IT Architecture

Stipe Fustar

6/11/2007

Experience you can trust.

Stipe Fustar: EPCC -- Ullensvang, Norway, June 11, 2007

Presentation Summary

- Brief Introduction to Integration, Service-Oriented and Event-Driven Architectures
- Some Context around SOA and Integration Technologies
 - Realities of Enterprise Systems
 - New Enterprise System Trends
 - Next Generation of Energy Systems – Considerations
 - SOA and CIM Usage Perspective
 - Vision of Standard Services

SOA Basics

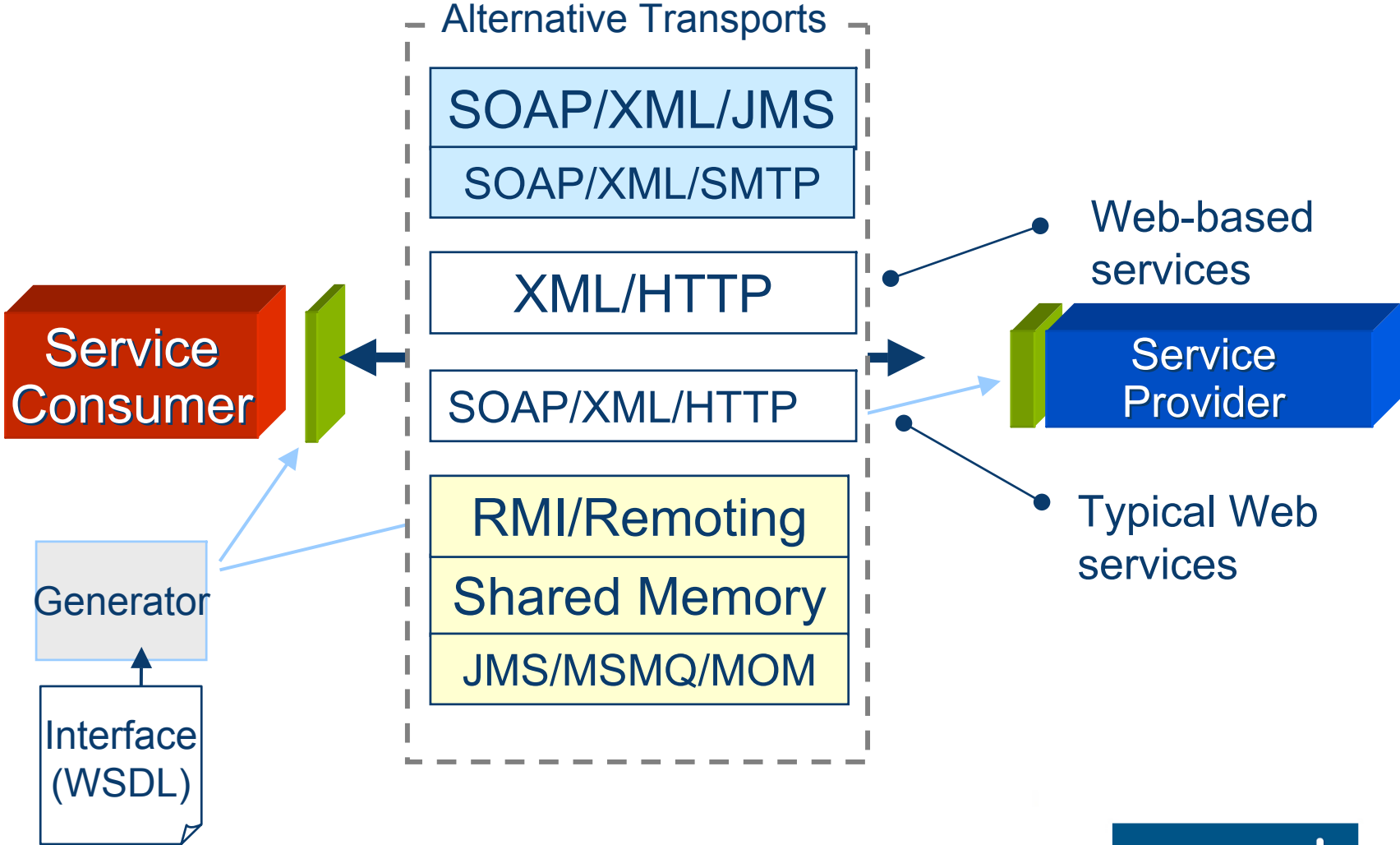

Courtesy of Gartner



Services Classification Overview

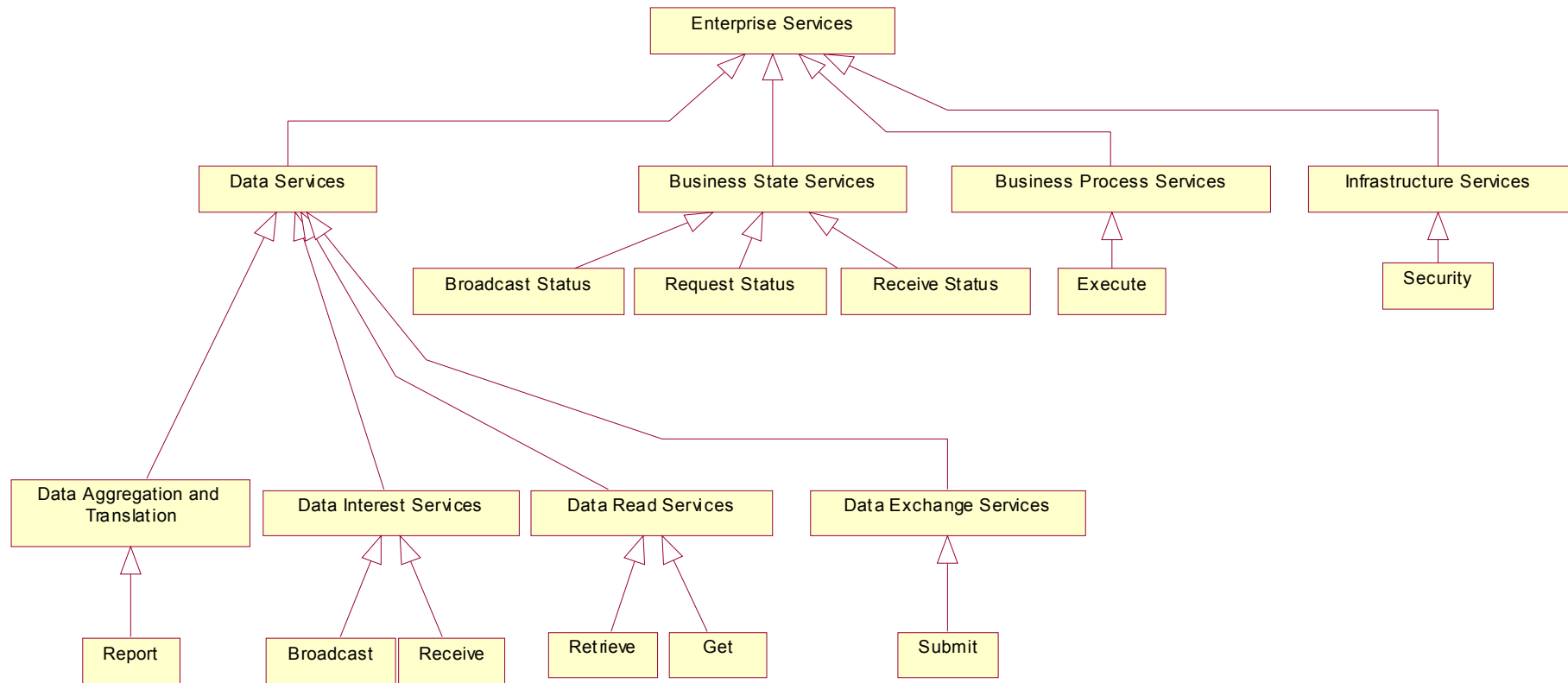

Enterprise Service Bus

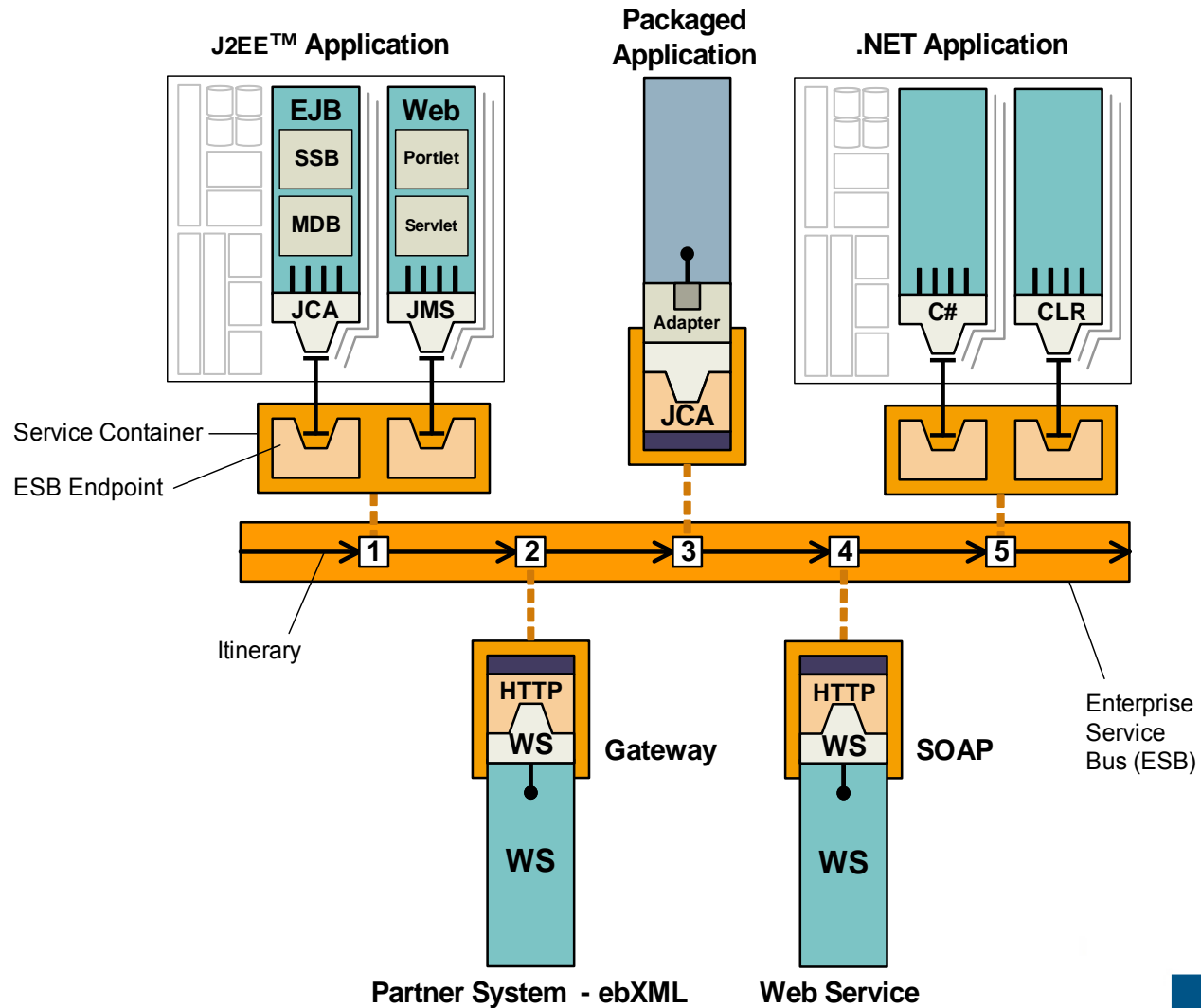

Template: Courtesy of Sonic Software



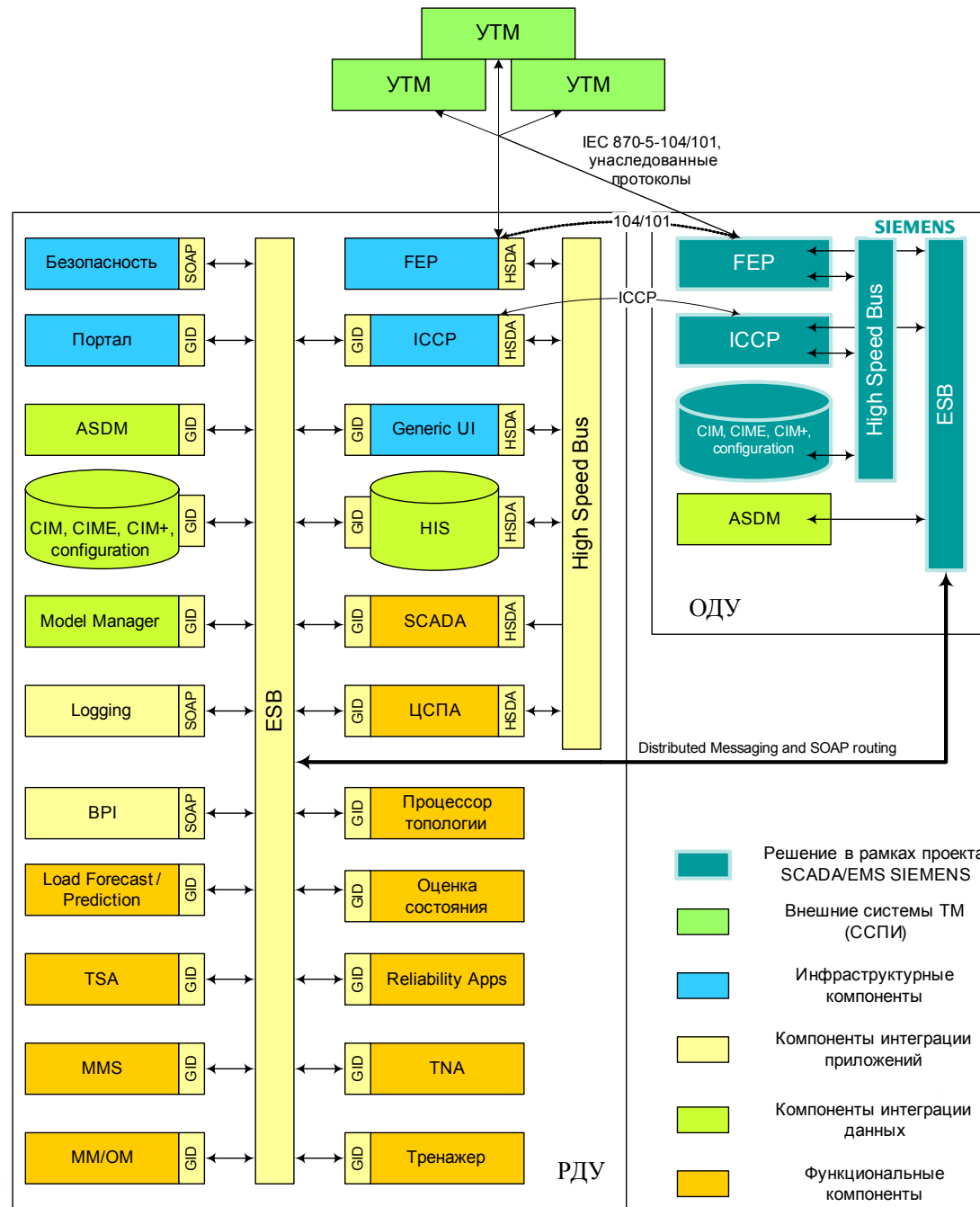

Source: SO-CDU



Event-Driven vs. Service-Oriented

Service-Oriented Architecture Interaction

- Consumer directs flow
- Linear path of execution
- Can not react to new external input once a flow is started

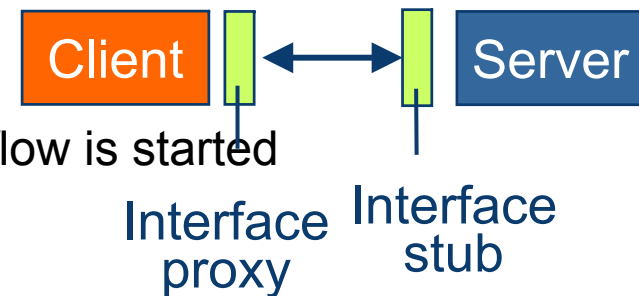

Event-Driven Notification

- Sink (recipient) determines flow
- Dynamic, parallel, asynchronous flows
- Can react to new external input while process is in flight



Courtesy of Gartner



Events Classification

Event Manager, Event Processing Agents

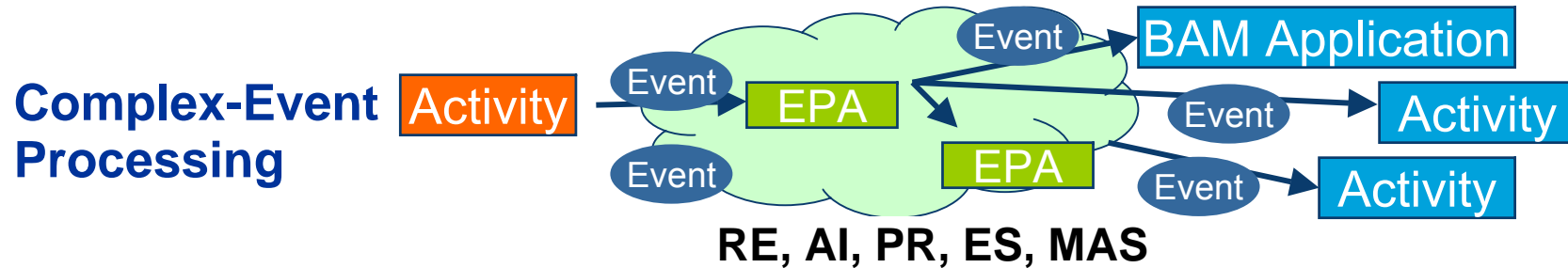

Event-Based BPM

Event-Enabled Processes

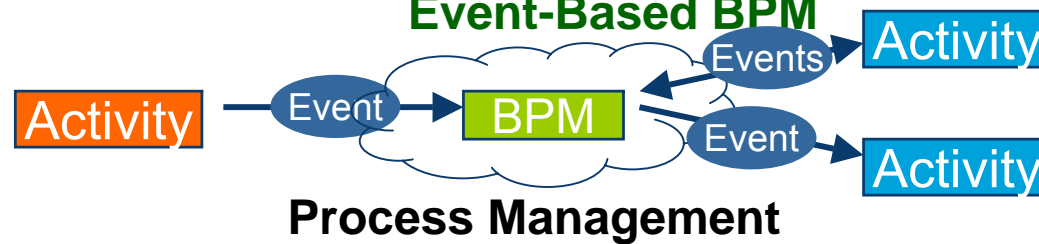

Integration Broker

Mediated Events

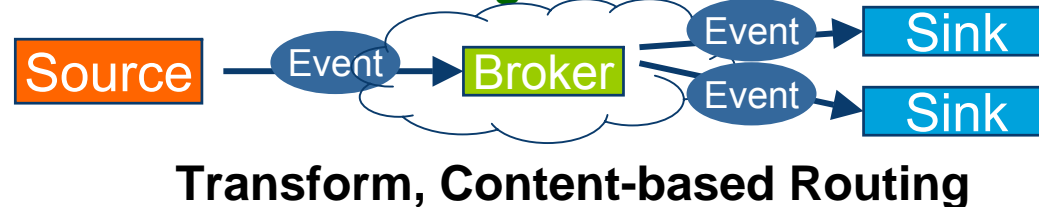

MOM, Web Services, ESB, E-Mail

Simple Events

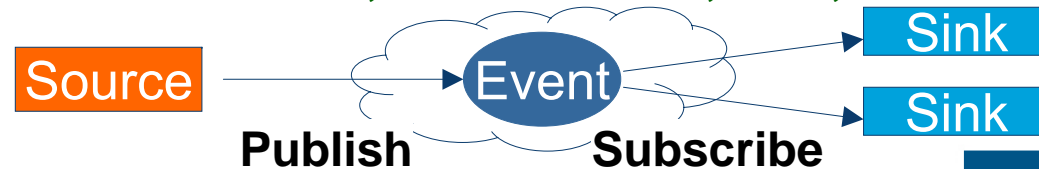

Courtesy of Gartner



Today's Realities of Enterprise Systems

- Systems are:
 - Too expensive to deploy and maintain
 - Too complicated and often difficult to use
 - Too monolithic:
 - They were built for the specific purpose and largely ignore the informational needs of the surrounding functional areas.
 - Not easy to integrate
- They are constraining the business efficiency
 - They are a bottle-neck for more effective business operations

New Enterprise Systems Trends (1)

- New Systems are expected to provide:
 - A revolutionary application platform that includes:
 - Standard-based Solutions,
 - SOA and EDA
 - Open Source as desired,
 - Ideally, Systems will be
 - Dramatically easy to use,
 - Highly Adaptable; Responsive to the often changing needs
 - Significantly lower Total Cost of Ownership
 - Built-to-integrate
 - Driven by industry standards



New Enterprise Systems Trends (2)

- Applications Industry shifts towards Open Standards
- Commitment to Standard is becoming a strong sell point
- Vendors dedicated to Open Standards are typically Market Leaders
- Visionary Companies will Target Traditional Market in non-traditional way
 - Configuration rather than coding

Next Generation of Energy Systems

- Leverages latest Integration Technologies
- Returns as Composite Application Framework
 - Fits into System of Systems Architecture
- Presents a new opportunity for vendors' collaboration
 - (Pre)-integrated Multi-Vendor Solutions
- Forces “built-to-integrate” approach
- **Requires new standards**



Utility Real-Estate

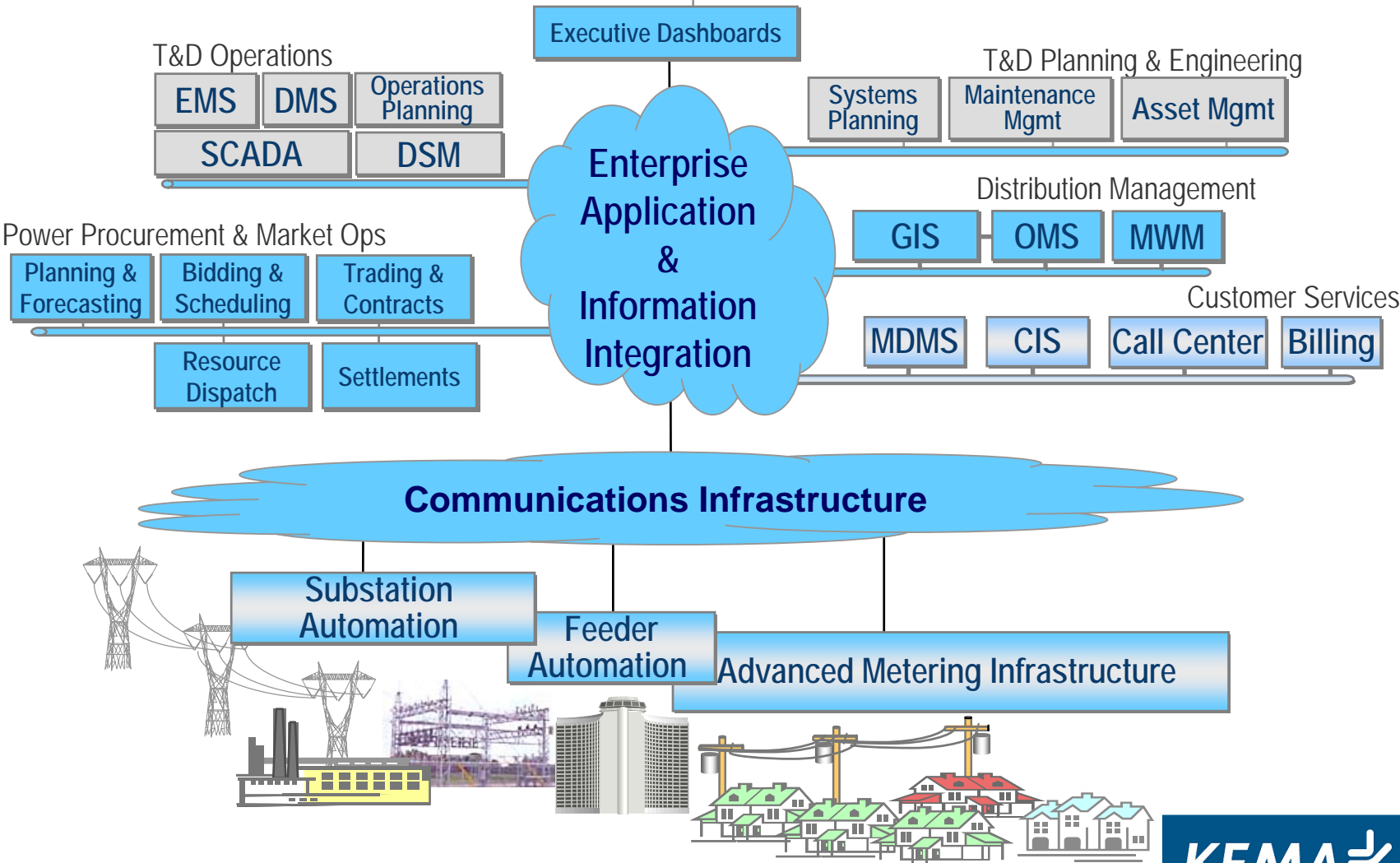

“(E/D/G/M)MS Cube”

Next Generation System Assemblies

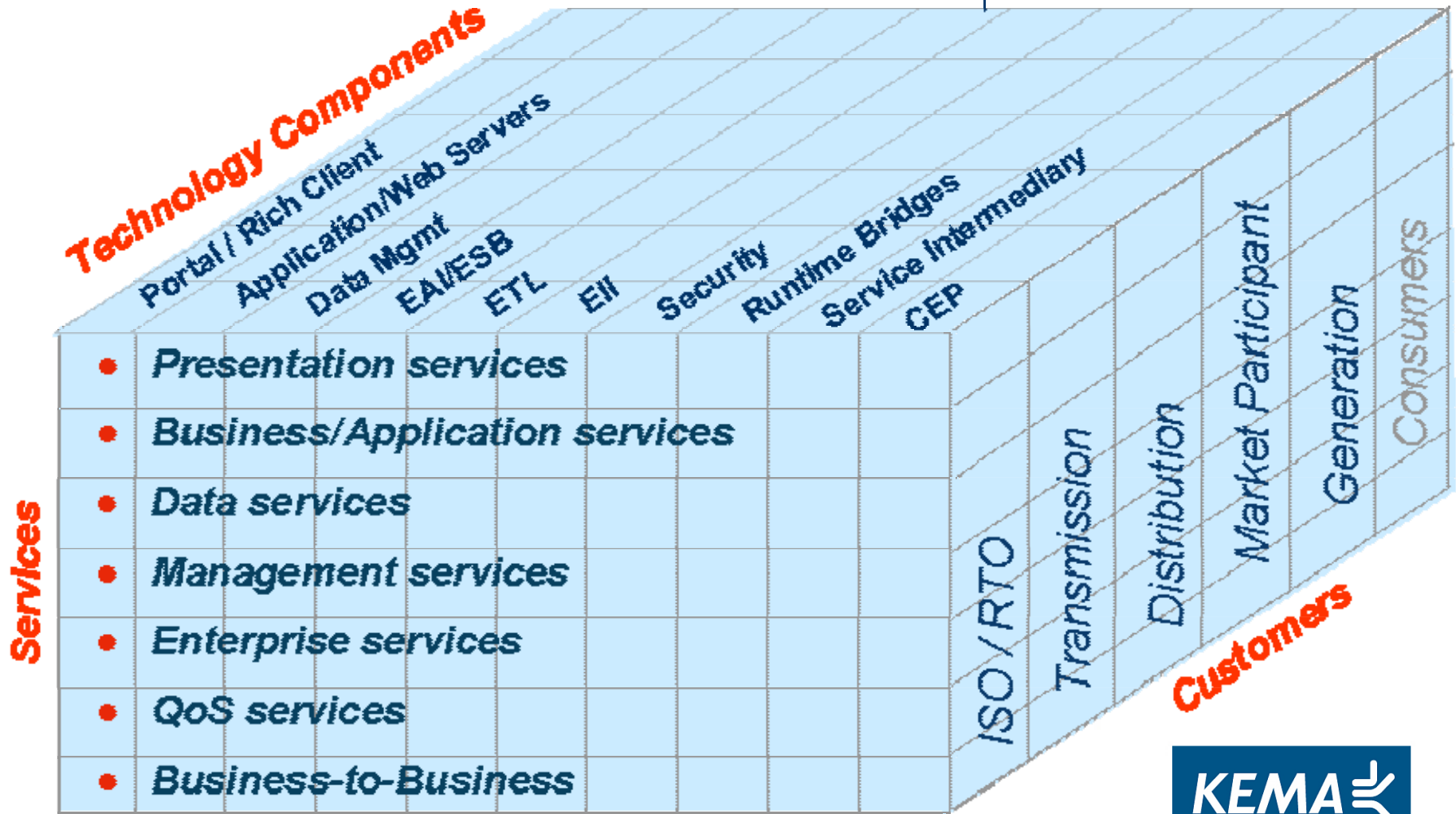

A Pre-Integrated Multi-Vendors Solution – ISO Example

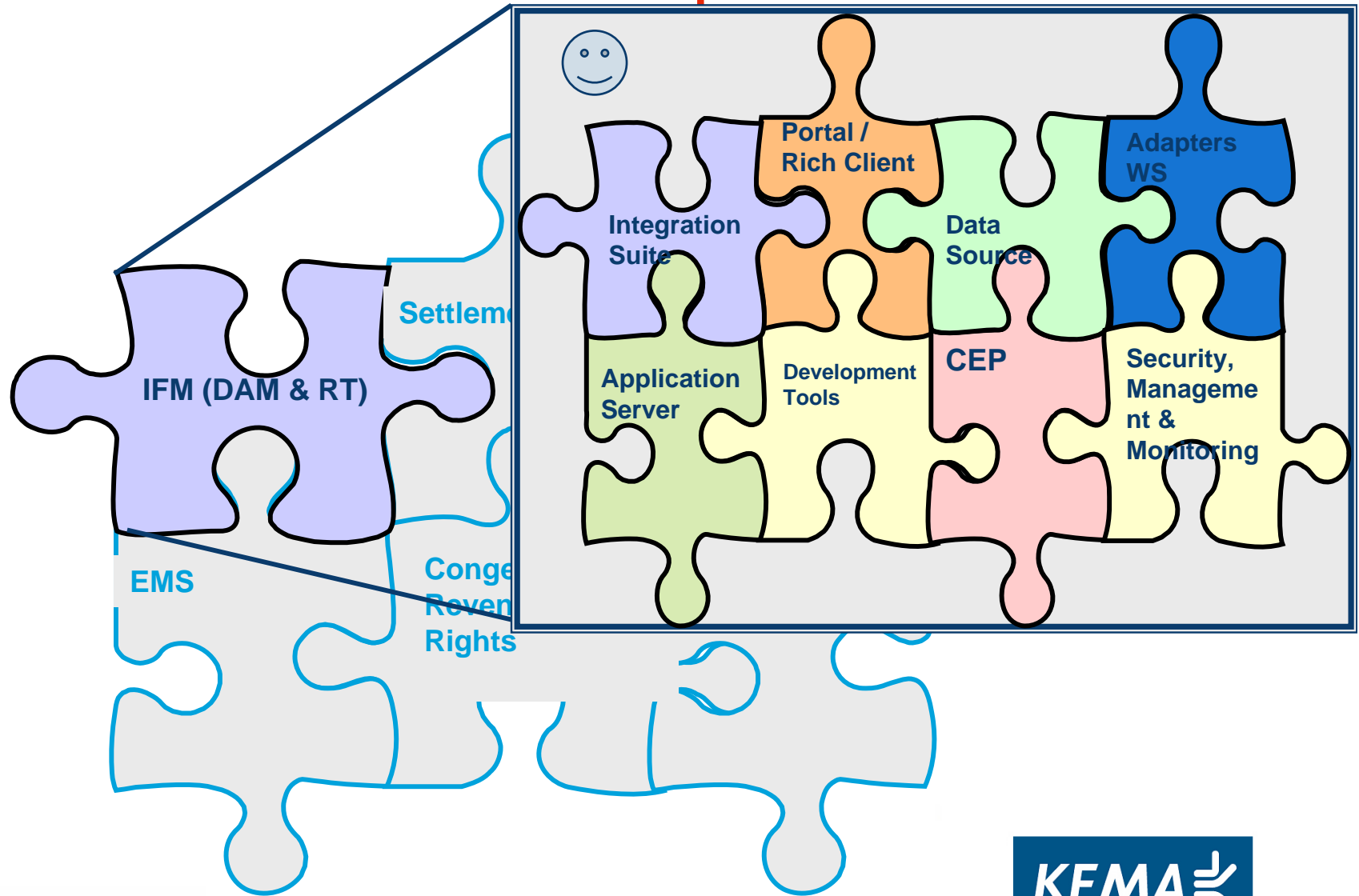

SOA and CIM Usage: Role of Patterns

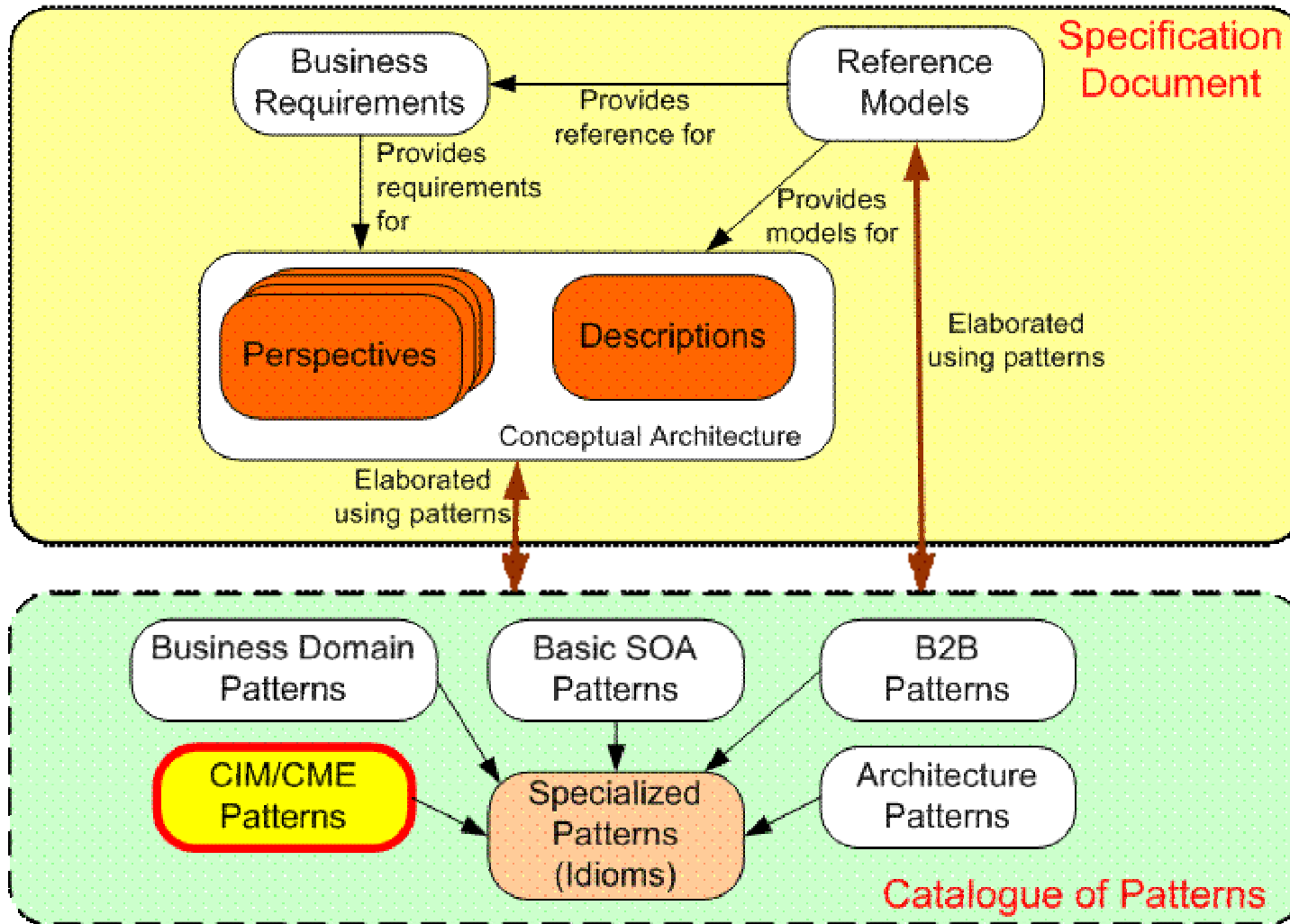

Why Patterns?

- Patterns describe architectural constructs / assemblies that work
- When used repeatedly a pattern becomes established as best practice.
- Patterns can be catalogued
- SOA and CIM Usage Patterns should be catalogued
 - Capture a structured description of SOA and CIM Usage
 - This will speed up and simplify CIM usage and SOA design and implementation
 - E.g XML Schema Message Payload generation from UML is a well-established Pattern with several flavors



Integration Pattern 1

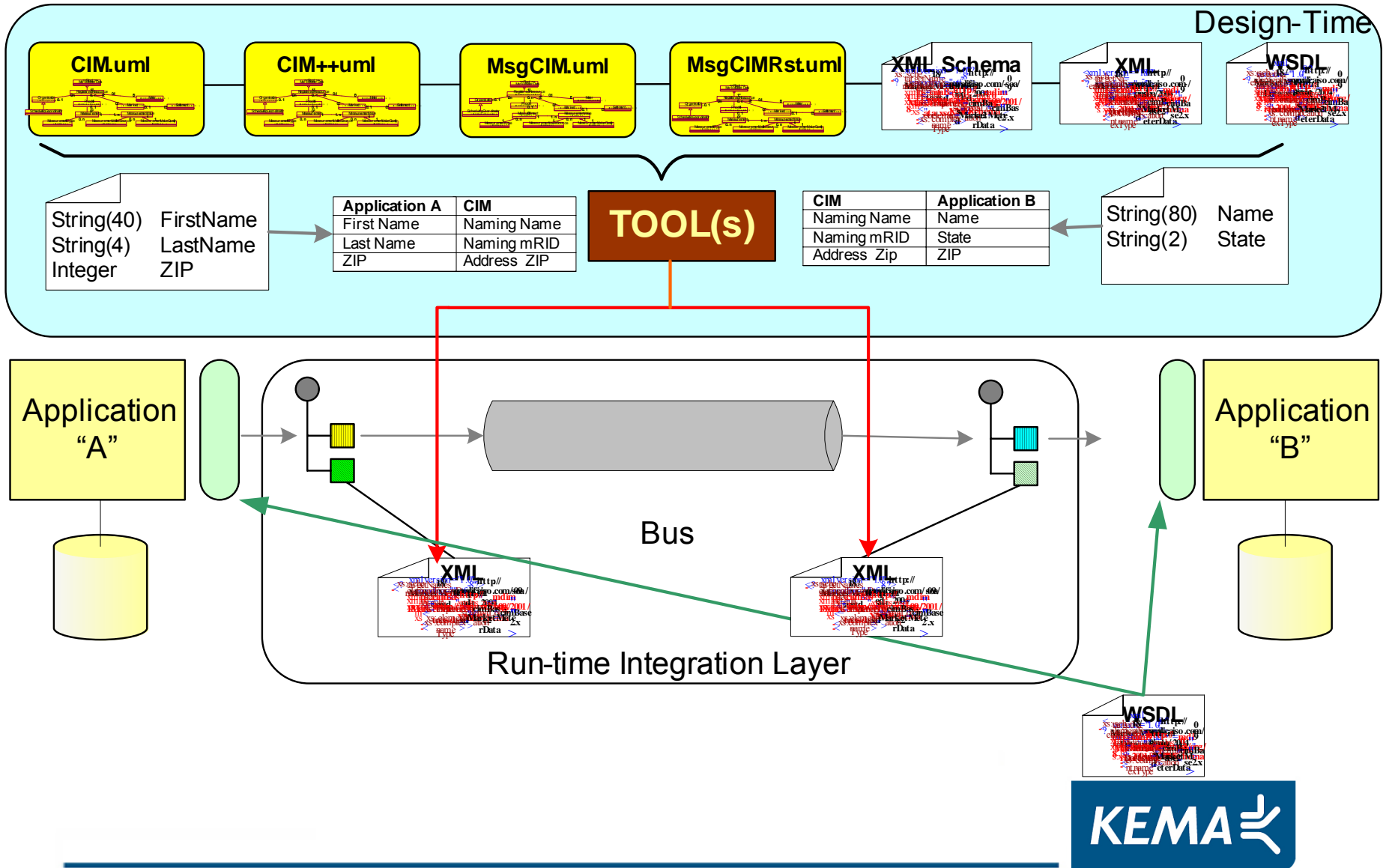

Some Patterns (1)

| Integration Pattern | Conceptual Diagram | Description |
|----------------------------------|--------------------|---------------------------------------------------------------------------------------------------------------------------------------------------------------------------------------------------------------------------------------------------------------------------------------------------------|
| Point-to-Point | | <ul style="list-style-type: none"> · Data Maintained Locally · Batch transfer or ETL <ul style="list-style-type: none"> - File Exchange - API · Data Duplication Potential |
| Point-to-Point via SOA | | <ul style="list-style-type: none"> · Requires <ul style="list-style-type: none"> - Service-enabled interfaces - Consumer side Development - SOA Components · Data still Maintained Locally and Still Data Duplication Potential |
| Traditional Message Bus Approach | | <ul style="list-style-type: none"> · Data Exchange via messages · Publish and subscribe · Transformation outside of the application systems · Data Duplication Potential · Need for Adapters |

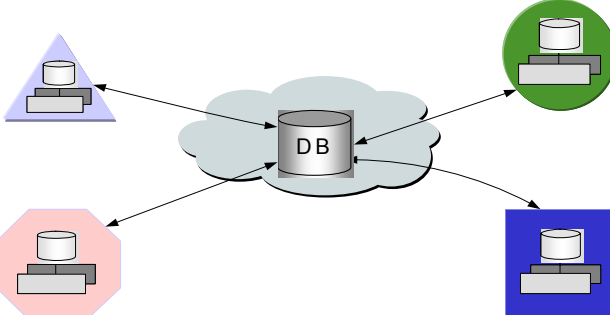
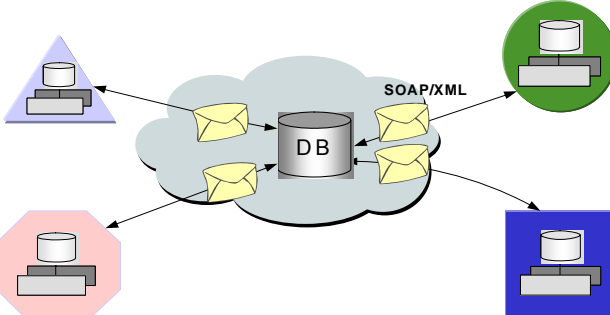
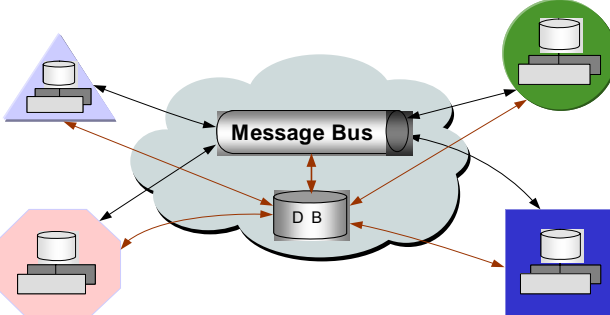

Some Patterns

| | | |
|-----------------------------|-------------------------------------------------------------------------------------|------------------------------------------------------------------------------------------------------------------------------------------------------------------------------------|
| <p>Data Sharing Pattern</p> |  | <ul style="list-style-type: none"> · Shared Database · RT Access to the latest Information · Data Consistency · Minimal Data Duplication |
| <p>Data Sharing via SOA</p> |  | <ul style="list-style-type: none"> · Data Access via Services · Data exchange and Notifications via SOAP/XML messages · SOA Infrastructure needed |
| <p>"Hybrid" Approach</p> |  | <ul style="list-style-type: none"> · Best of Both Worlds |

SOA and Role of CIM?

- CIM role is becoming more and more important
 - Customers
 - Vendors
 - Consultants
- Help solution architects with SOA Usage patterns
- Be aware of ultimate objective
 - With all interfaces / services defined and implemented, integration is a configuration (“connecting dots”) exercise

Vision Of Standard Services

- Leverages CIM
 - All payloads are either forward engineered from CIM or mapped to CIM
- Standard Services
 - WSDL
 - Message payloads
 - XML Schema
 - XML Templates (message instances – send/response)
 - GID
- Benefits
 - True Plug-And-Play functionality
 - Publicly Available
 - Easy Interoperability Testing
 - Can be provided On-line



Questions?

More Information?

Sfustar@kema.com

